

MINISTRY USE ONLY



Place Personal Education Number (PEN) here.



**Physics 12**

**AUGUST 2005**

**Course Code = PH**



**Physics 12**

**AUGUST 2005**

**Course Code = PH**

**BRITISH  
COLUMBIA**

### **Student Instructions**

1. Place the stickers with your Personal Education Number (PEN) in the allotted spaces above. **Under no circumstance is your name or identification, other than your Personal Education Number, to appear on this booklet.**
2. Ensure that in addition to this examination booklet, you have a **Data Booklet** and an **Examination Response Form**. Follow the directions on the front of the Response Form.
3. **Disqualification** from the examination will result if you bring books, paper, notes or unauthorized electronic devices into the examination room.
4. When instructed to open this booklet, **check the numbering of the pages** to ensure that they are numbered in sequence from page one to the last page, which is identified by  

**END OF EXAMINATION**

.
5. At the end of the examination, place your Response Form inside the front cover of this booklet and return the booklet and your Response Form to the supervisor.

MINISTRY USE ONLY

--

Place Personal Education Number (PEN) here.

 <input type="text"/> 
---

## Physics 12

**AUGUST 2005**

**Course Code = PH**

Question 1									
0	1	2	3	4	5		(.5)	NR	
<input type="checkbox"/>	<input type="checkbox"/>	<input type="checkbox"/>	<input type="checkbox"/>	<input type="checkbox"/>	<input type="checkbox"/>		<input type="checkbox"/>	<input type="checkbox"/>	
Question 2									
0	1	2	3	4	5		(.5)	NR	
<input type="checkbox"/>	<input type="checkbox"/>	<input type="checkbox"/>	<input type="checkbox"/>	<input type="checkbox"/>	<input type="checkbox"/>		<input type="checkbox"/>	<input type="checkbox"/>	
Question 3									
0	1	2	3	4	5	6		(.5)	NR
<input type="checkbox"/>	<input type="checkbox"/>	<input type="checkbox"/>	<input type="checkbox"/>	<input type="checkbox"/>	<input type="checkbox"/>	<input type="checkbox"/>		<input type="checkbox"/>	<input type="checkbox"/>
Question 4									
0	1	2	3	4	5		(.5)	NR	
<input type="checkbox"/>	<input type="checkbox"/>	<input type="checkbox"/>	<input type="checkbox"/>	<input type="checkbox"/>	<input type="checkbox"/>		<input type="checkbox"/>	<input type="checkbox"/>	
Question 5									
0	1	2	3	4	5		(.5)	NR	
<input type="checkbox"/>	<input type="checkbox"/>	<input type="checkbox"/>	<input type="checkbox"/>	<input type="checkbox"/>	<input type="checkbox"/>		<input type="checkbox"/>	<input type="checkbox"/>	
Question 6									
0	1	2	3	4			(.5)	NR	
<input type="checkbox"/>	<input type="checkbox"/>	<input type="checkbox"/>	<input type="checkbox"/>	<input type="checkbox"/>			<input type="checkbox"/>	<input type="checkbox"/>	



## GENERAL INSTRUCTIONS

1. Aside from an approved calculator, electronic devices, including dictionaries and pagers, are **not** permitted in the examination room.
2. Ensure that your calculator is in degree mode.
3. All multiple-choice answers must be entered on the Response Form using an **HB pencil**. Multiple-choice answers entered in this examination booklet will **not** be marked.
4. For each of the written-response questions, write your answer in the space provided in this booklet. Rough-work space has been incorporated into the space allowed for answering each written-response question. You may not need all of the space provided to answer each question.
5. Ensure that you use language and content appropriate to the purpose and audience of this examination. Failure to comply may result in your paper being awarded a zero.
6. This examination is designed to be completed in **two hours**. *Students may, however, take up to 30 minutes of additional time to finish.*

## PHYSICS 12 PROVINCIAL EXAMINATION

- |   | Value            | Suggested Time     |
|---|------------------|--------------------|
| 1. This examination consists of <b>two</b> parts:         |                  |                    |
| PART A: 35 multiple-choice questions worth two marks each | 70 marks         | 70 minutes         |
| PART B: 6 written-response questions                      | 30 marks         | 50 minutes         |
| <b>Total:</b>   | <b>100 marks</b> | <b>120 minutes</b> |
2. The last **three** pages inside the back cover contain the **Fundamental Constants and Physical Data, Mathematical Formulae, Physical Formulae, and Rough Work for Multiple-Choice**. These pages may be detached for convenient reference prior to writing this examination.
3. **A calculator is essential for the Physics 12 Provincial Examination.** The calculator must be a hand-held device designed primarily for mathematical computations involving logarithmic and trigonometric functions and may be capable of performing graphing functions. Computers, calculators with a QWERTY keyboard or symbolic manipulation abilities, and electronic writing pads will not be allowed. Students must not bring any external devices (peripherals) to support calculators such as manuals, printed or electronic cards, printers, memory expansion chips or cards, CD-ROMs, libraries or external keyboards. Students may have more than one calculator available during the examination, of which one may be a scientific calculator. Calculators may not be shared and must not have the ability to either transmit or receive electronic signals. In addition to an approved calculator, students will be allowed to use rulers, compasses, and protractors during the examination.
4. a) Final answers must include appropriate **units**.  
b) Marks will not be deducted for answers expressed to **two** or **three** significant figures.  
c) In this examination the zero in a number such as 30 shall be considered to be a significant zero.
5. You are expected to communicate your knowledge and understanding of physics principles in a clear and logical manner. Partial marks will be awarded for steps and assumptions leading to a solution. Full marks will **not** be awarded for providing **only** a final answer.

If you are unable to determine the value of a quantity required in order to proceed, you may assume a reasonable value and continue toward the solution. Such a solution, however, may not be eligible for full marks.

**THIS PAGE INTENTIONALLY BLANK**

## PART A: MULTIPLE CHOICE

Value: 70 marks (2 marks per question)

Suggested Time: 70 minutes

**INSTRUCTIONS:** For each question, select the **best** answer and record your choice on the Response Form provided. Using an HB pencil, completely fill in the circle that has the letter corresponding to your answer.

- Which of the following correctly applies to a projectile in the absence of friction?
  - The vertical velocity is changing.
  - The horizontal velocity is changing.
  - The vertical acceleration is changing.
  - The horizontal acceleration is changing.
- An 1800 kg car initially travelling at 15 m/s brakes to avoid hitting another car. The car accelerates at  $-1.9 \text{ m/s}^2$  while braking to a stop. How far does the car travel during its acceleration?
  - 29 m
  - 59 m
  - 120 m
  - 180 m
- A 15 kg rock is projected horizontally from a very high cliff at a speed of 65 m/s as shown.

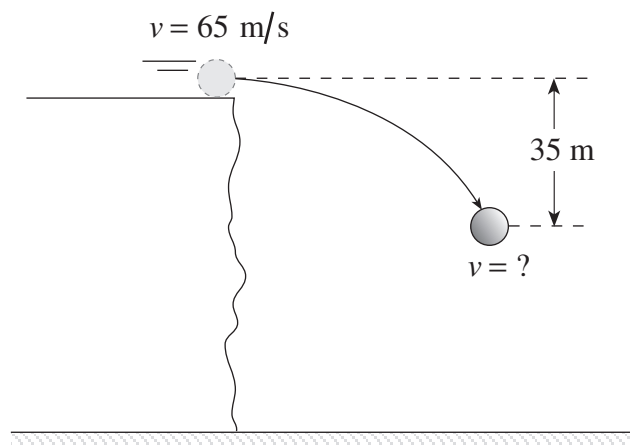

What is the speed of the rock after it has fallen a vertical distance of 35 m?

- 26 m/s
- 59 m/s
- 65 m/s
- 70 m/s

4. Which of the following is equal to the gravitational field strength?

- A.  $F_g$
- B.  $\frac{m}{F_g}$
- C.  $\frac{F_g}{m}$
- D.  $F_g \times m$

5. A cart of unknown mass is attached to a 2.2 kg mass hanging over the edge of a table as shown. The cart accelerates at  $3.0 \text{ m/s}^2$ . (Ignore friction.)

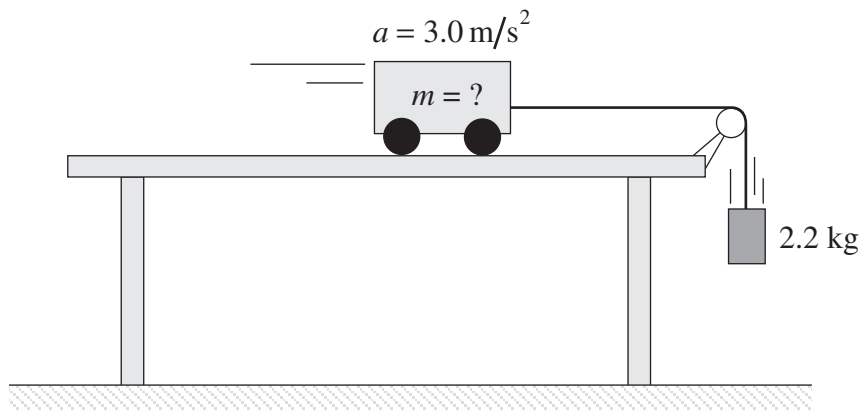

What is the mass of the cart?

- A. 1.2 kg
- B. 5.0 kg
- C. 6.6 kg
- D. 7.2 kg

6. What force  $F$  applied parallel to the incline would make the 15 kg block shown below move at a constant speed up the incline?

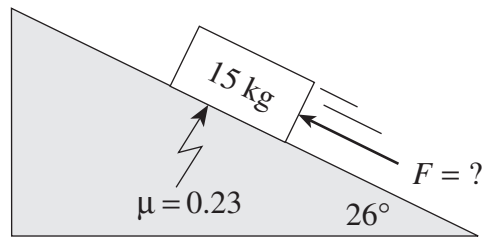

- A. 30 N  
 B. 34 N  
 C. 64 N  
 D. 95 N
7. A ball is dropped from a tree and falls to the ground. Which of the following best represents the ball's total energy,  $E_T$ , as it falls?

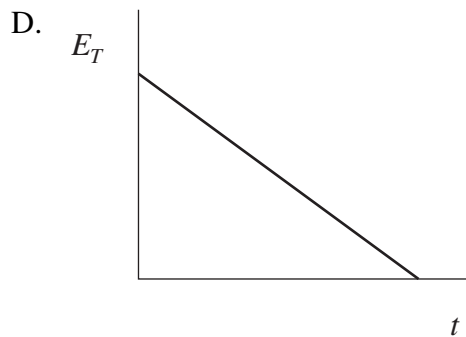
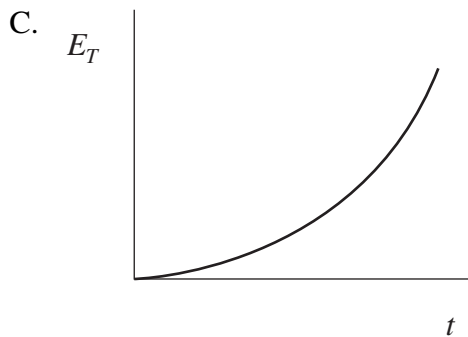
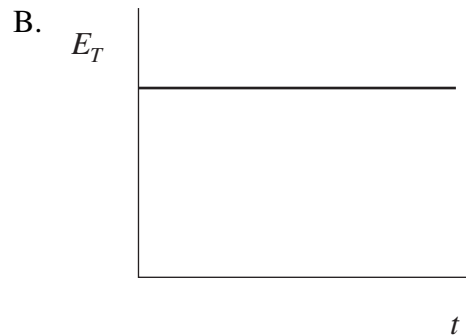
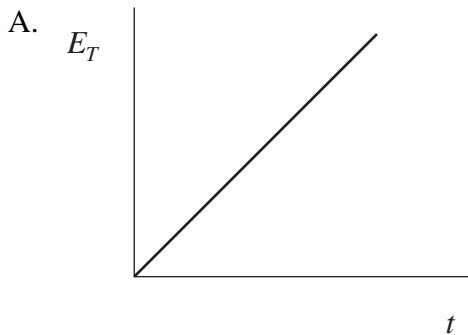



8. A 45 kg steel ball is projected vertically with an initial speed of 280 m/s. While the ball is rising,  $8.5 \times 10^5$  J of heat energy are produced due to air friction. What is the maximum height reached by the ball?

- A. 1900 m
- B. 2100 m
- C. 4000 m
- D. 5900 m

9. The force  $F$  shown below is pulling the mass  $m$  over a frictionless surface with an acceleration of  $a$ .

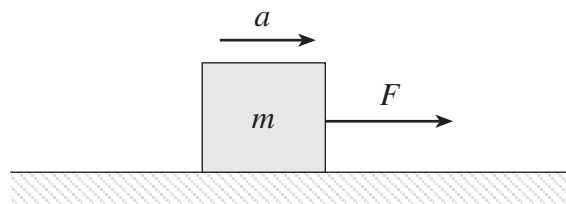

Which of the following is equal to the mass's rate of change of momentum?

- A.  $F$
- B.  $\frac{F}{a}$
- C.  $\frac{F}{m}$
- D.  $F \cdot a$

10. A 5.0 kg ice block is sliding along a smooth floor at 1.0 m/s west when a 0.20 N force directed east acts on it for 4.0 s. What is the magnitude of the block's final momentum?

- A. 0.80 kg m/s
- B. 4.2 kg m/s
- C. 5.0 kg m/s
- D. 5.8 kg m/s

11. A 1.0 kg physics puck is at rest when a small explosion breaks it into three pieces. A 0.50 kg piece goes north at 10 m/s and a 0.30 kg piece goes east at 20 m/s. What is the magnitude of the momentum of the third piece?
- A. 1.0 kg m/s  
 B. 3.3 kg m/s  
 C. 7.8 kg m/s  
 D. 11 kg m/s

12. Which of the following demonstrates the application of torque?
- A. Pulling a block across a floor  
 B. Pushing a block up an incline  
 C. Using a screwdriver to turn a screw  
 D. Stopping a block from sliding down an incline

13. What are the tensions  $T_1$  and  $T_2$  in the two ropes holding the 36 kg mass as shown?

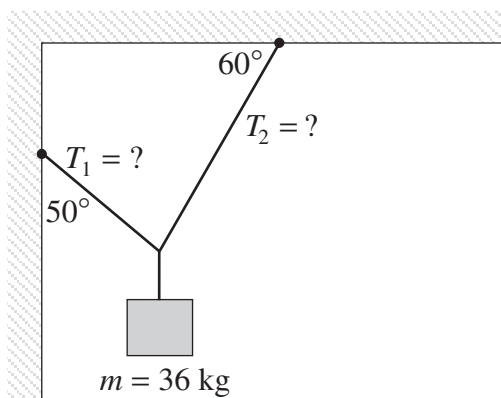

	TENSION $T_1$	TENSION $T_2$
A.	180 N	180 N
B.	180 N	270 N
C.	350 N	180 N
D.	350 N	350 N

14. Two cables are used to support a 24 kg mass on a 1.6 m long 8.0 kg uniform horizontal beam as shown.

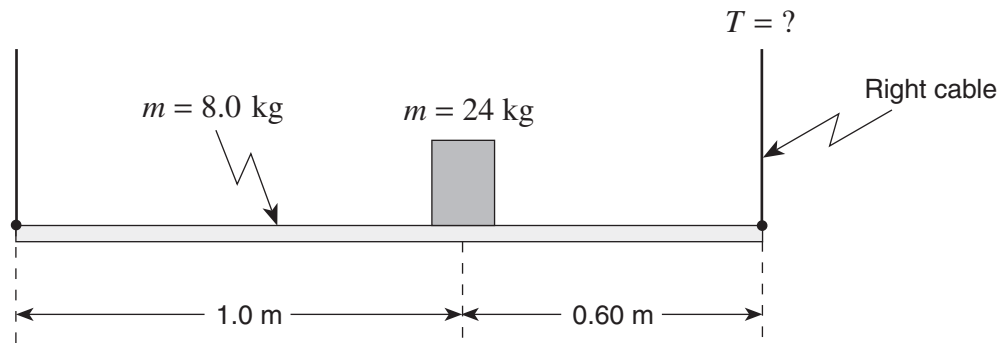

What is the tension  $T$  in the right cable?

- A. 130 N
  - B. 150 N
  - C. 190 N
  - D. 300 N
15. A 1.6 kg ball is held in the hand of a fully extended 11.2 kg arm as shown.  
(cg = centre of gravity)

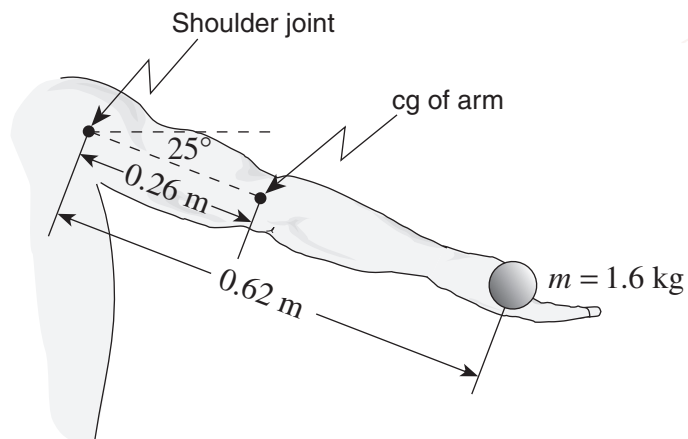

What is the total torque about the shoulder joint due to the ball and to this arm?

- A. 17 N·m
- B. 19 N·m
- C. 35 N·m
- D. 38 N·m

16. A small spider is accidentally taking a ride on a CD rotating with a period  $T$ . Its centripetal acceleration is  $10 \text{ m/s}^2$ . The CD player is turned off and the disc slows down. What is the spider's centripetal acceleration when the disc has slowed so the period is  $2T$ ?

- A.  $2.5 \text{ m/s}^2$
- B.  $5.0 \text{ m/s}^2$
- C.  $20 \text{ m/s}^2$
- D.  $40 \text{ m/s}^2$

17. The  $2.5 \text{ kg}$  lead mass shown below is moving in a horizontal circle. The tension in the line is  $30 \text{ N}$ .

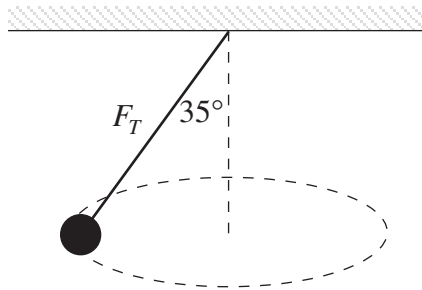

What is the centripetal force on the lead mass?

- A.  $17 \text{ N}$
- B.  $25 \text{ N}$
- C.  $30 \text{ N}$
- D.  $55 \text{ N}$

18. A car is going around a curve at constant speed on a level road as shown in the diagram below.

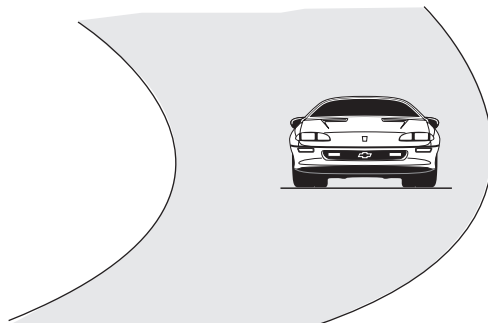

Which of the following free body diagrams shows the forces acting on the car?

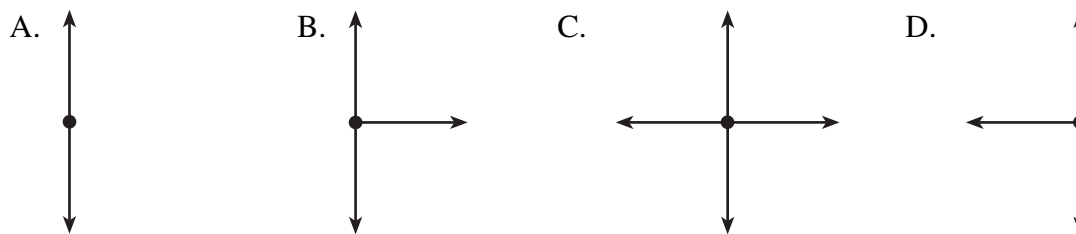

19. A satellite is in a circular orbit around a planet. Which of the following describes the magnitude of the force due to gravity on the satellite as it moves around the planet?

- A. constant
- B. increasing
- C. decreasing
- D. increasing then decreasing

20. A planet has a larger gravitational field strength on its surface than does the earth. Which of the following is a possible comparison of this planet's mass and radius with Earth's?

	MASS	RADIUS
A.	larger	equal
B.	equal	larger
C.	smaller	equal
D.	smaller	larger

21. The force due to gravity between two masses ( $m_1$  and  $m_2$ ) is determined for several separation distances. This data is then used to create the graph below. What is the slope of this graph?

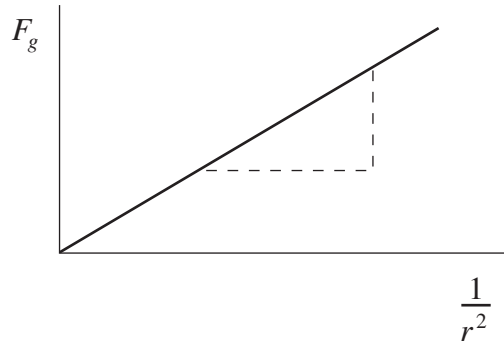

- A.  $G$
- B.  $m_1m_2$
- C.  $\frac{m_1m_2}{G}$
- D.  $Gm_1m_2$
22. What is the speed of a 500 kg satellite orbiting the moon at distance of  $2.5 \times 10^6$  m from the moon's centre?
- A. 0.89 m/s
- B. 20 m/s
- C.  $1.4 \times 10^3$  m/s
- D.  $3.1 \times 10^4$  m/s

23. A mass is launched from the surface of a large moon at high speed. Which of the following graphs shows the potential and kinetic energies of the mass as it moves away from the moon?

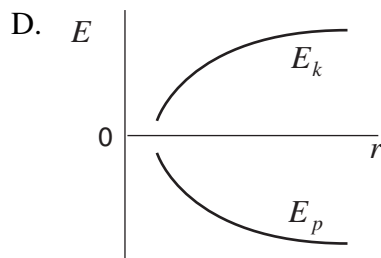
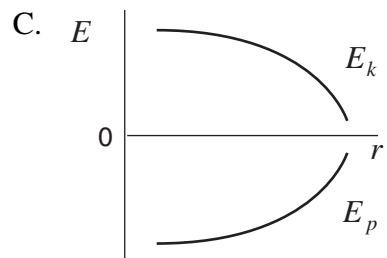
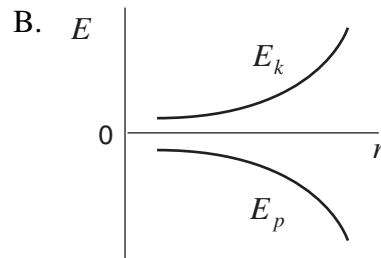
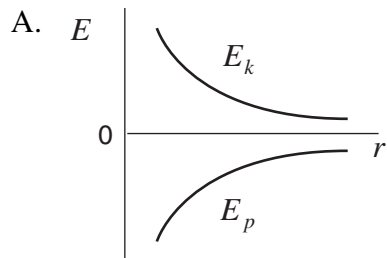

24. Which diagram best illustrates the electric field between oppositely charged parallel plates?

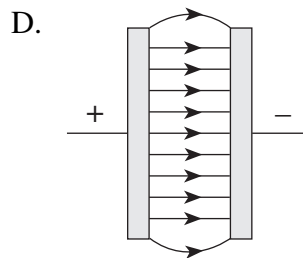
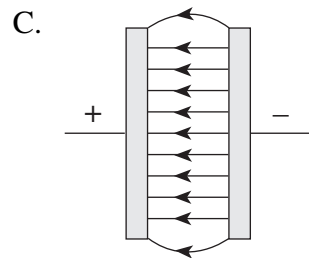
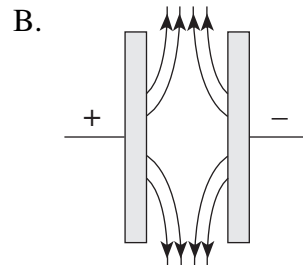
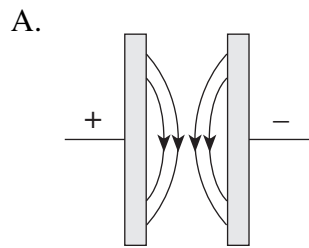

25. Three charges of identical magnitude are arranged as shown.

$Q_1 \oplus$

$Q_2 \oplus$

$\ominus Q_3$

What is the direction of the electric force on  $Q_2$ ?

A.



B.

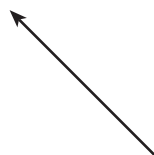

C.



D.

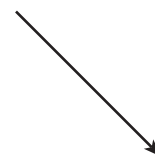

26. Identical  $12\mu\text{C}$  charges are placed at the ends of a metre stick.

$12\mu\text{C}$   
 $\oplus$



$12\mu\text{C}$   
 $\oplus$

What is the electric potential at point P at the 60 cm mark on the metre stick?

A.  $9.0 \times 10^4 \text{ V}$

B.  $3.8 \times 10^5 \text{ V}$

C.  $4.5 \times 10^5 \text{ V}$

D.  $9.8 \times 10^5 \text{ V}$



27. What is the internal resistance of the battery if it delivers 1.5 A when connected to a  $3.0 \Omega$  external load?

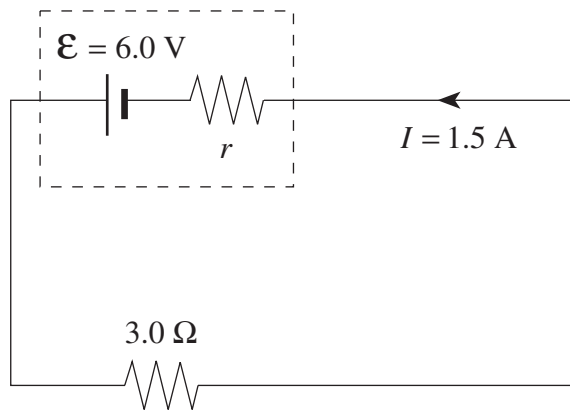

- A.  $1.0 \Omega$
- B.  $3.0 \Omega$
- C.  $4.0 \Omega$
- D.  $7.0 \Omega$

28. In the circuit below, what is the current through the  $2.0 \Omega$  resistor?

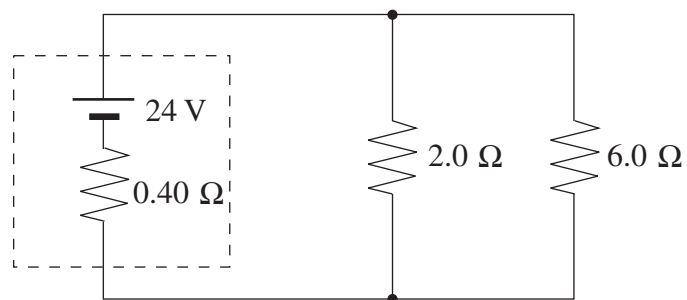

- A. 9.5 A
- B. 10 A
- C. 12 A
- D. 13 A

29. Which set groups the three common household electrical appliances in increasing order of rate of energy consumption while operating?

	INCREASING RATE OF ENERGY CONSUMPTION		
A.	desktop computer	toaster	oven
B.	desktop computer	oven	toaster
C.	toaster	oven	desktop computer
D.	toaster	desktop computer	oven

30. In a step-down transformer, which of the following is greater in the secondary than in the primary?

- A. power
- B. current
- C. voltage
- D. number of turns

31. Two identical bar magnets are placed as shown.

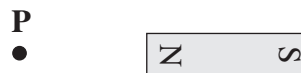

What is the direction of the magnetic field at P?

- A.
- B.
- C.
- D.

32. A current of 4.3 A flows through a solenoid. The 620-turn solenoid is 14 cm long and has a 3.5 cm diameter.

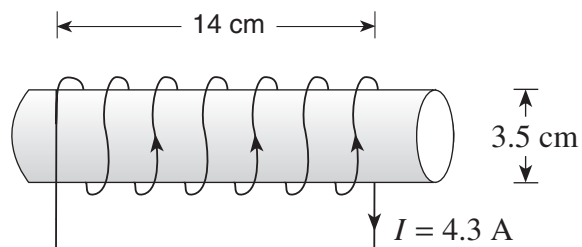

What are the direction and magnitude of the magnetic field inside the solenoid?

	DIRECTION OF FIELD	MAGNETIC FIELD STRENGTH (T)
A.	left	$2.4 \times 10^{-2}$
B.	left	$9.6 \times 10^{-2}$
C.	right	$2.4 \times 10^{-2}$
D.	right	$9.6 \times 10^{-2}$

33. A conductor is moved to the right through four magnetic fields as shown below. In which case will the largest emf be generated?

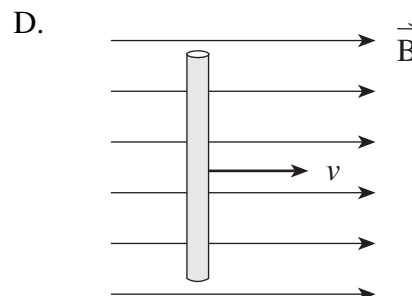
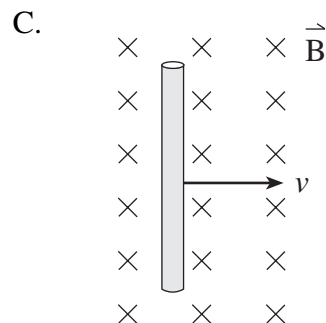
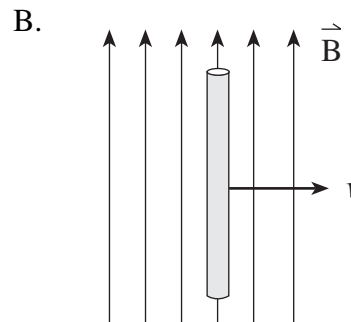
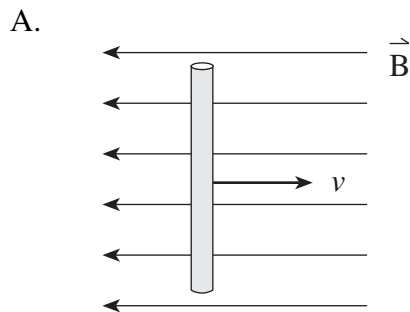

34. A bar magnet is moved away from a coil as shown. What is the direction of the current through the resistor and the polarity of the left end of the coil?

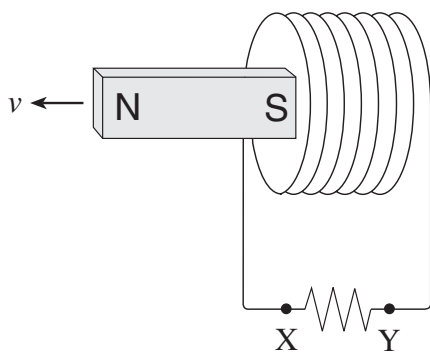

	DIRECTION OF CURRENT THROUGH THE RESISTOR	POLARITY OF LEFT END OF COIL
A.	X to Y	North
B.	X to Y	South
C.	Y to X	North
D.	Y to X	South

35. A 200-turn coil has a 15.2 V potential difference induced in it when the magnetic field changes from 0.42 T to 0.22 T in the opposite direction in  $3.2 \times 10^{-2}$  s. What is the radius of this coil?

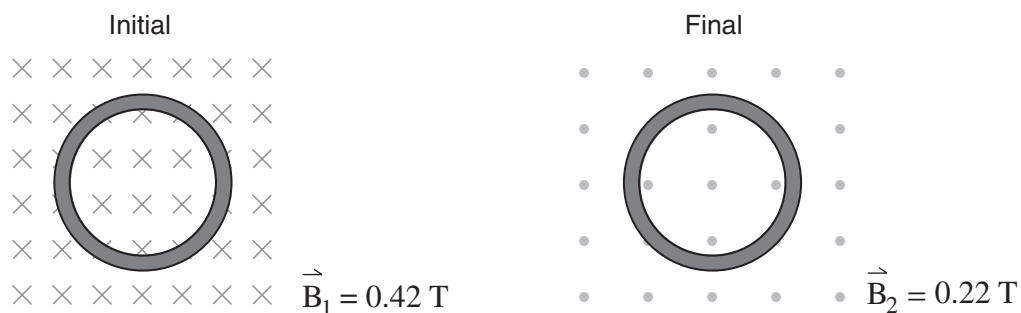

- A.  $3.5 \times 10^{-2}$  m  
 B.  $5.1 \times 10^{-2}$  m  
 C.  $5.9 \times 10^{-2}$  m  
 D.  $6.2 \times 10^{-2}$  m

**This is the end of the multiple-choice section.**  
**Answer the remaining questions directly in this examination booklet.**

**THIS PAGE INTENTIONALLY BLANK**

## PART B: WRITTEN RESPONSE

Value: 30 marks

Suggested Time: 50 minutes

### INSTRUCTIONS:

1. Rough-work space has been incorporated into the space allowed for answering each written-response question. You may not need all of the space provided to answer each question.
2.
  - a) Final answers must include appropriate **units**.
  - b) Marks will not be deducted for answers expressed to **two** or **three** significant figures.
  - c) In this examination the zero in a number such as 30 shall be considered to be a significant zero.
3. You are expected to communicate your knowledge and understanding of physics principles in a clear and logical manner. Partial marks will be awarded for steps and assumptions leading to a solution.
4. If you are unable to determine the value of a quantity required in order to proceed, you may assume a reasonable value and continue toward the solution. Such a solution, however, may not be eligible for full marks.
5. **Full marks will NOT be awarded for providing only a final answer.**

1. A hammer slides down a roof sloped at  $35^\circ$  reaching a speed of  $4.6 \text{ m/s}$  before falling off.

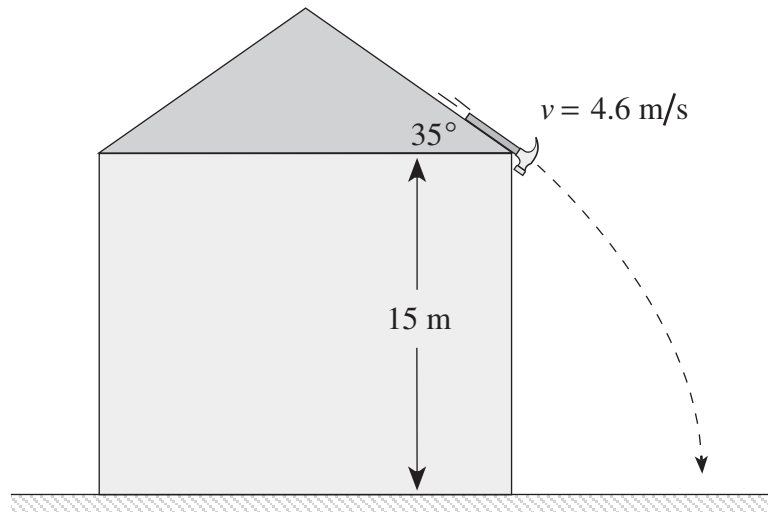

How much time does it take to fall the  $15 \text{ m}$  to the ground?

**(5 marks)**

ANSWER:

time: \_\_\_\_\_



2. A 65 kg man is 3.0 m up a 5.0 m, 16 kg ladder leaning against a smooth wall at an angle of  $72^\circ$  as shown below.

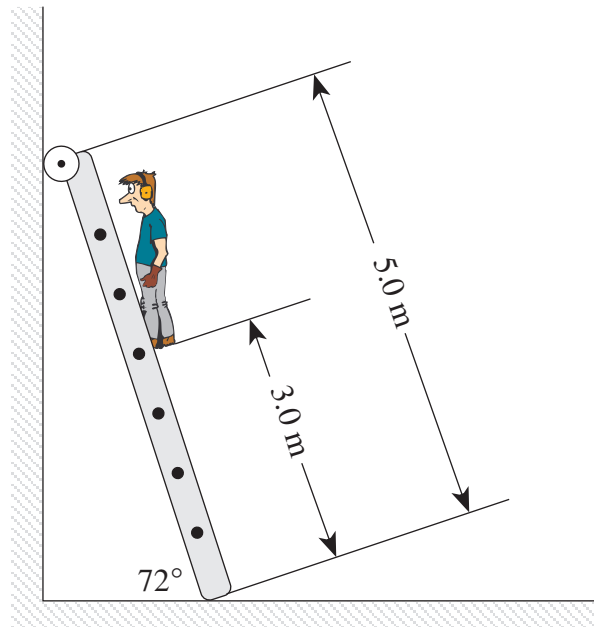

What minimum force of friction between the ladder and the floor is required to keep the ladder from sliding? **(5 marks)**

ANSWER:

minimum force: \_\_\_\_\_

3. Alpha particles with a mass of  $6.6 \times 10^{-27}$  kg and a charge of  $3.2 \times 10^{-19}$  C are fired towards each other from a great distance.

$$m = 6.6 \times 10^{-27} \text{ kg}$$

⊕ →

$$Q = 3.2 \times 10^{-19} \text{ C}$$

$$m = 6.6 \times 10^{-27} \text{ kg}$$

← ⊕

$$Q = 3.2 \times 10^{-19} \text{ C}$$

- a) If they each have a speed of  $2.5 \times 10^6$  m/s to start with, what will be their minimum separation distance? **(4 marks)**

ANSWER:

a) minimum separation distance: \_\_\_\_\_

- b) Using energy principles, explain why the particles do not come any closer than this minimum separation distance. **(2 marks)**

---

---

---

---

---

---

---

4. A 0.75 m metal rod is suspended as shown. A current of 13 A then flows as indicated.

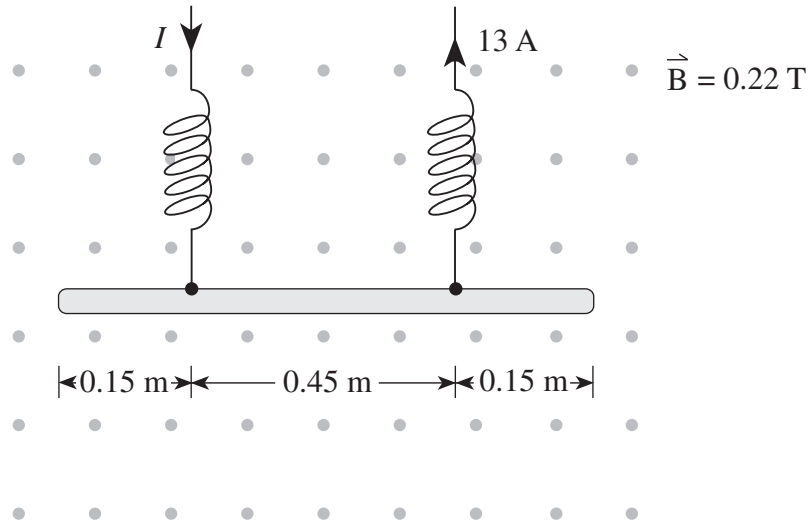

a) Is the tension in the springs increased or decreased? **(1 mark)**

---

b) How much does the tension change? **(4 marks)**

ANSWER:

b) tension change: \_\_\_\_\_

5. An experiment was performed on the surface of an asteroid. A mass was dropped from various heights and the time taken to fall was recorded.

d(m)	t(s)	$t^2(s^2)$
0	0	
0.50	1.31	
0.70	1.56	
0.90	1.77	
1.20	2.05	
1.30	2.15	

- a) Plot a straight line graph of  $d$  vs.  $t^2$ .

**(2 marks)**

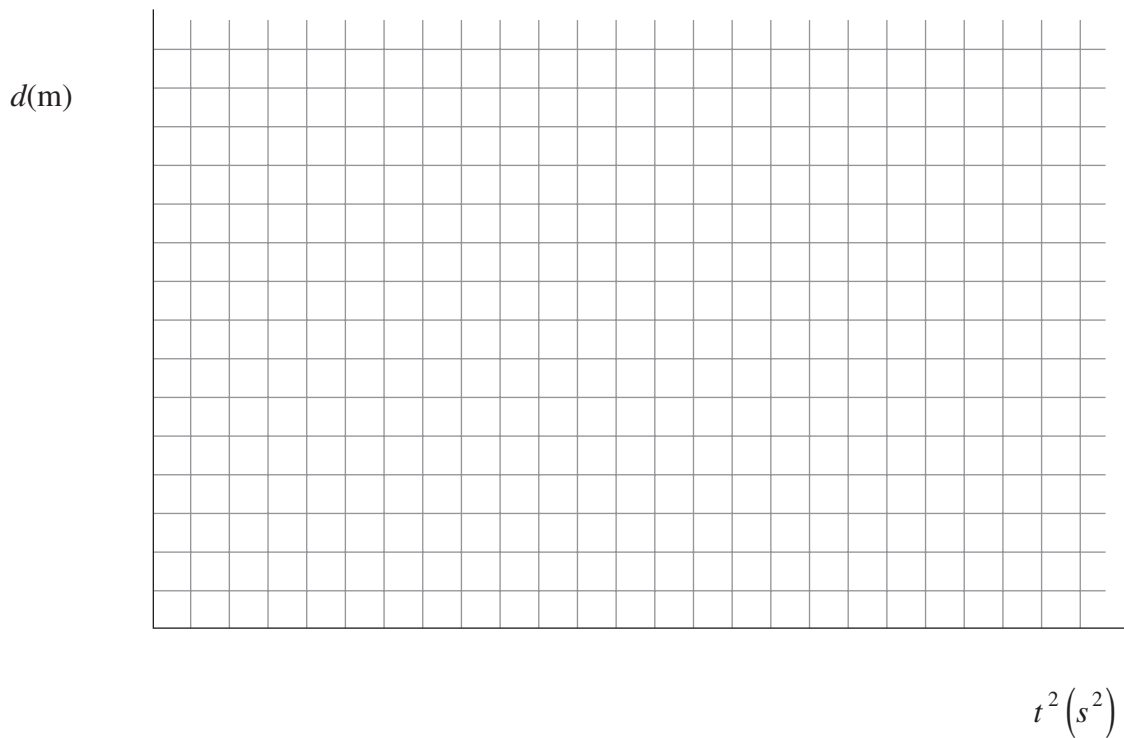

- b) From your straight line graph, determine the slope of the line. (Include units.) **(1 mark)**

ANSWER:

b) slope of the line: \_\_\_\_\_

- c) What is the acceleration due to gravity on the surface of this asteroid? **(2 marks)**

ANSWER:

c) acceleration due to gravity: \_\_\_\_\_



6. When checked with a voltmeter, an old 6 V lantern battery shows the expected reading of 6.0 V. However, the battery fails to light a low resistance light bulb. Identify the property of the battery that must have changed as it aged.

---

Explain why this change to the property results in the bulb no longer lighting. **(4 marks)**

---

---

---

---

**END OF EXAMINATION**

## FUNDAMENTAL CONSTANTS AND PHYSICAL DATA

Gravitational constant.....	$G = 6.67 \times 10^{-11} \text{ N} \cdot \text{m}^2/\text{kg}^2$
Constant in Coulomb's Law.....	$k = 9.00 \times 10^9 \text{ N} \cdot \text{m}^2/\text{C}^2$
Elementary charge .....	$e = 1.60 \times 10^{-19} \text{ C}$
Mass of electron.....	$m_e = 9.11 \times 10^{-31} \text{ kg}$
Mass of proton.....	$m_p = 1.67 \times 10^{-27} \text{ kg}$
Permeability of free space .....	$\mu_o = 4\pi \times 10^{-7} \text{ T} \cdot \text{m}/\text{A}$
Speed of light .....	$c = 3.00 \times 10^8 \text{ m/s}$
<b>Earth</b>	
radius .....	$= 6.38 \times 10^6 \text{ m}$
mass .....	$= 5.98 \times 10^{24} \text{ kg}$
acceleration due to gravity at the surface of Earth (for the purposes of this examination) .....	$g = 9.80 \text{ m/s}^2$
period of rotation .....	$= 8.61 \times 10^4 \text{ s}$
radius of orbit around Sun.....	$= 1.50 \times 10^{11} \text{ m}$
period of orbit around Sun .....	$= 3.16 \times 10^7 \text{ s}$
<b>Moon</b>	
radius .....	$= 1.74 \times 10^6 \text{ m}$
mass .....	$= 7.35 \times 10^{22} \text{ kg}$
period of rotation .....	$= 2.36 \times 10^6 \text{ s}$
radius of orbit around Earth .....	$= 3.84 \times 10^8 \text{ m}$
period of orbit around Earth.....	$= 2.36 \times 10^6 \text{ s}$
<b>Sun</b>	
mass .....	$= 1.98 \times 10^{30} \text{ kg}$

**You may detach this page for convenient reference.  
Exercise care when tearing along perforations.**

# MATHEMATICAL FORMULAE

METRIC PREFIXES			
Prefix	Symbol	Numerical	Exponential
mega	M	1,000,000	$10^6$
kilo	k	1,000	$10^3$
hecto	h	100	$10^2$
deca	da	10	$10^1$
		1	$10^0$
deci	d	0.1	$10^{-1}$
centi	c	0.01	$10^{-2}$
milli	m	0.001	$10^{-3}$
micro	$\mu$	0.000001	$10^{-6}$

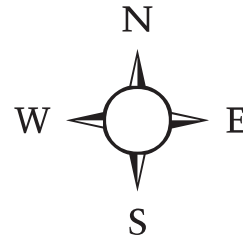

### For Right-angled Triangles:

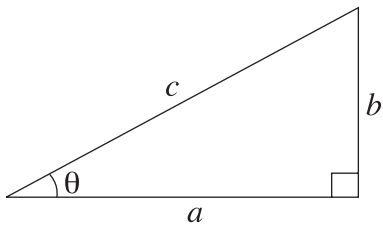

$$a^2 + b^2 = c^2$$

$$\sin \theta = \frac{b}{c} \quad \cos \theta = \frac{a}{c} \quad \tan \theta = \frac{b}{a}$$

$$\text{area} = \frac{1}{2} ab$$

### For All Triangles:

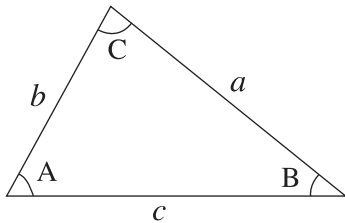

$$\text{area} = \frac{1}{2} \text{base} \times \text{height}$$

$$\text{Sine Law:} \quad \frac{\sin A}{a} = \frac{\sin B}{b} = \frac{\sin C}{c}$$

$$\text{Cosine Law:} \quad c^2 = a^2 + b^2 - 2ab \cos C$$

### Circle:

$$\text{Circumference} = 2\pi r$$

$$\text{Area} = \pi r^2$$

### Quadratic Equation:

$$\text{If } ax^2 + bx + c = 0, \text{ then } x = \frac{-b \pm \sqrt{b^2 - 4ac}}{2a}$$

## PHYSICS FORMULAE

### Vector Kinematics in Two Dimensions:

$$v = v_0 + at \quad \bar{v} = \frac{v + v_0}{2}$$

$$v^2 = v_0^2 + 2ad \quad d = v_0t + \frac{1}{2}at^2$$

### Vector Dynamics:

$$F_{\text{net}} = ma \quad F_g = mg$$

$$F_{\text{fr}} = \mu F_N$$

### Work, Energy, and Power:

$$W = Fd \quad E_p = mgh$$

$$E_k = \frac{1}{2}mv^2 \quad P = \frac{W}{\Delta t}$$

### Momentum:

$$p = mv \quad \Delta p = F\Delta t$$

### Equilibrium:

$$\tau = Fd$$

### Circular Motion:

$$T = \frac{1}{f}$$

$$a_c = \frac{v^2}{r} = \frac{4\pi^2 r}{T^2}$$

### Gravitation:

$$F = G \frac{m_1 m_2}{r^2} \quad E_p = -G \frac{m_1 m_2}{r}$$

### Electrostatics:

$$F = k \frac{Q_1 Q_2}{r^2} \quad E = \frac{F}{Q} \quad E = \frac{kQ}{r^2}$$

$$\Delta V = \frac{\Delta E_p}{Q} \quad E = \frac{\Delta V}{d}$$

$$E_p = k \frac{Q_1 Q_2}{r} \quad V = \frac{kQ}{r}$$

### Electric Circuits:

$$I = \frac{Q}{\Delta t} \quad V = IR$$

$$V_{\text{terminal}} = \mathcal{E} \pm Ir \quad P = VI$$

### Electromagnetism:

$$F = BIl \quad F = QvB$$

$$B = \mu_0 n I = \mu_0 \frac{N}{l} I \quad \mathcal{E} = Blv$$

$$\Phi = BA \quad \mathcal{E} = -N \frac{\Delta \Phi}{\Delta t}$$

$$V_{\text{back}} = \mathcal{E} - Ir$$

$$\frac{V_s}{V_p} = \frac{N_s}{N_p} = \frac{I_p}{I_s}$$

**You may detach this page for convenient reference.  
Exercise care when tearing along perforations.**

**THIS PAGE INTENTIONALLY BLANK**

**ROUGH WORK FOR MULTIPLE-CHOICE**

**You may detach this page for convenient reference.  
Exercise care when tearing along perforations.**

# ROUGH WORK FOR MULTIPLE-CHOICE





