

Physics 11
M. Lam

Mystery Resistor Lab

Name:

Partner:

Block:

Objective

Construct a simple circuit and use multimeter measurements to determine an unknown resistance

Equipment

Battery
Wire
Digital multimeter
Resistor

Experimental Method

1. Construct the circuit shown in Figure 1.

Mystery Resistor Identifier: _____

2. Use a digital multimeter to measure the voltage of the battery and the voltage across the resistor (Figure 2).

Voltage of battery: _____

Voltage across resistor: _____

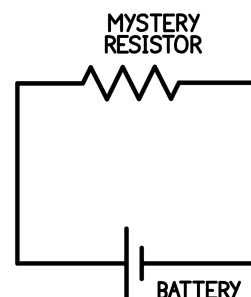

Figure 1: A simple circuit to be constructed for the lab

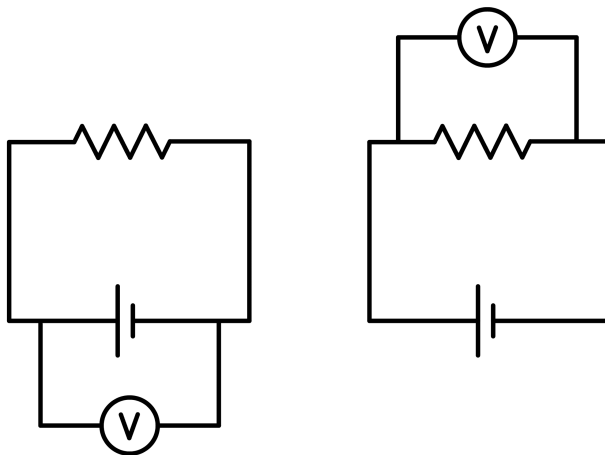

Figure 2: A digital multimeter will be used to measure the voltage of the battery and the voltage across the resistor.

How to use a voltmeter:

1. Connect one lead to the port labelled COM and the other to the port labelled V.
2. Turn the knob of the multimeter to measure DC voltage. *DC is represented by a straight line and AC is represented by a wavy line.*
3. Connect the leads of the voltmeter across two points in your circuit, parallel to the component you wish to measure voltage across. For example, if you want to measure the voltage of the battery, connect one lead “before” the battery and one lead “after” the battery.
4. If necessary, adjust the knob to the smallest voltage range which does not max out. *Some digital multimeters have an auto-ranging capability which automatically detects the correct range.*

3. Use a digital multimeter to measure the current at the two locations shown (Figure 3). **Make sure the ammeter is connected properly. An improperly connected ammeter can cause damage to the ammeter. See the instructions below and check if you are unsure.**

Current at Location 1: _____

Current at Location 2: _____

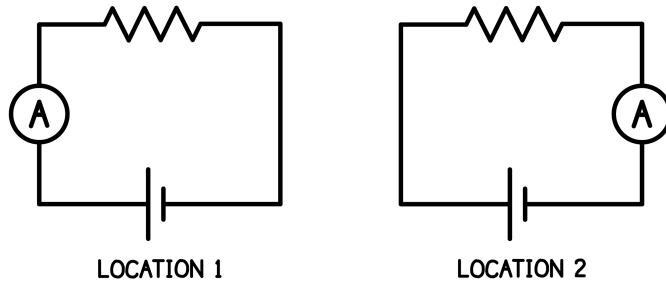

Figure 3: A digital multimeter will be used to measure the current at two locations in the circuit.

How to use an ammeter:

1. Connect one lead to the port labelled COM and the other to the port labelled mA. *The port labelled A is used for large currents. The maximum current each can handle is indicated next to the port.*
2. Turn the knob of the multimeter to measure DC current.
3. Unplug a wire to make an opening in the circuit at the location you wish you place the ammeter.
4. Connect the leads of the ammeter to the two sides of the opening, in series with the component you wish to measure the current through.
5. If necessary, adjust the knob to the smallest current range which does not max out.

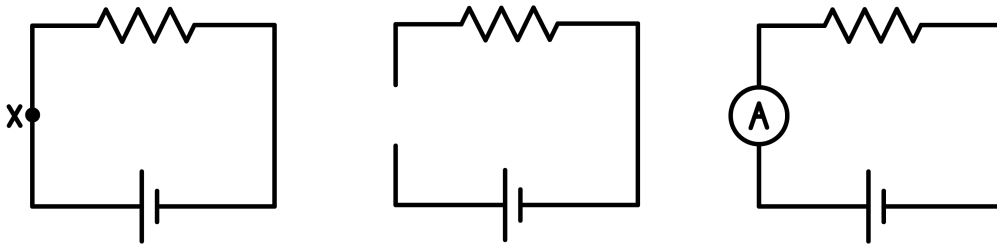

Figure 4: To measure the current at point X in the circuit, an opening is made at the point by disconnecting a wire. The ammeter is placed in the opening.

Analysis and Discussion

1. How does the measured voltage of the battery compare with the voltage across the resistor? Explain.

2. How the the current at location 1 compare to the current at location 2? Explain.

3. Use the voltage and current measurements to determine the resistance of the mystery resistor.