

## Breadboard Circuits

Name:

Partner:

Block:

### What is a breadboard?

A breadboard is a base for prototyping electronics. Resistors and other components can be inserted in the holes which are connected under the surface with metal strips. A breadboard makes connecting components and wires easier and more organized.

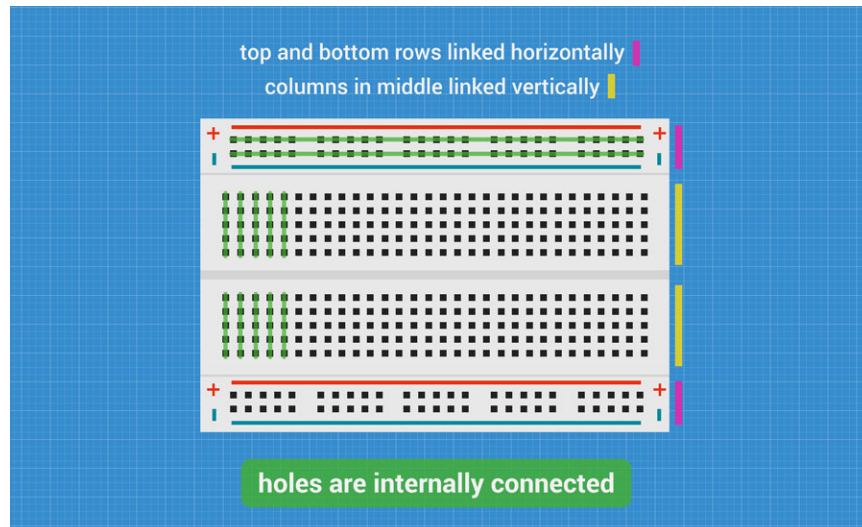

### What is an LED?

A light-emitting diode (LED) is a semiconductor light source that emits light when current flows through it. A diode is an electronic component that allows current to flow in only one direction. Current only flows from the positive side (anode) to the negative side (cathode). You can recognize the anode pin on a LED by the slightly longer length than the cathode pin.

Besides polarity being an important issue, it is equally important to add a resistor to restrict the current. The resistor we need depends on what voltage the power source has that we will be using. A diode needs a minimum specific voltage (voltage drop) across it before it will allow current to pass through it. If you don't add a resistor to the circuit, the LED will break because there is too much current flowing through it.

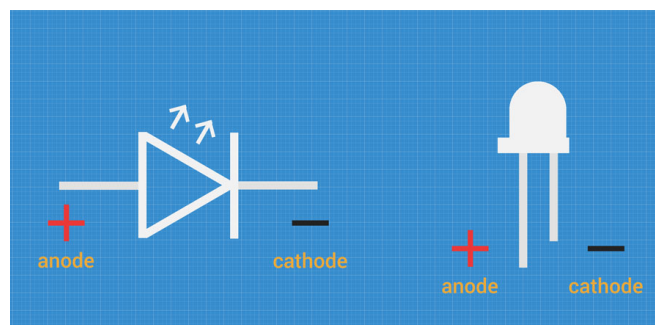

### What is a pushbutton?

A pushbutton has four terminals with each terminal already connected internally with its opposing terminal. When pressed, all four terminals are connected.

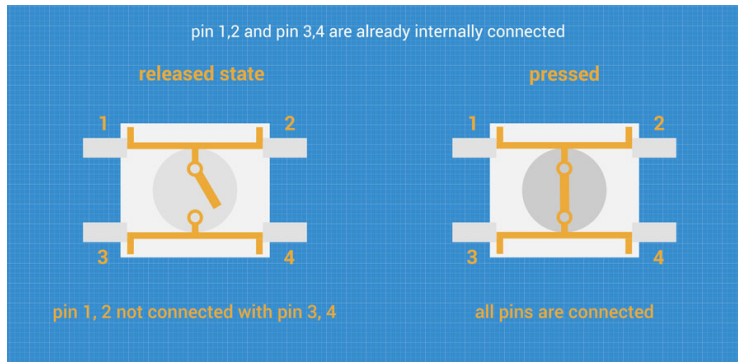

### What is a slide switch?

A slide switch is a component that is used to toggle a connection. It can be used to switch between two conductive paths where the current will only flow through the chosen path, or in some cases to prevent any current from flowing at all (when one of the connections of the slide switch isn't connected to anything).

A slide switch has three terminals in total. The position of the handle determines which one of the two outer terminals will be connected to the center terminal.

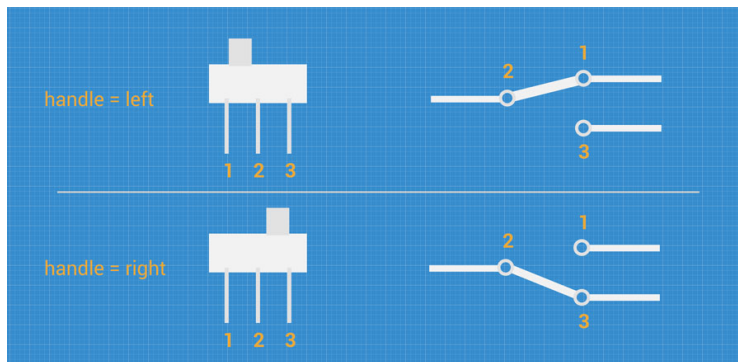

For each of the challenges, in addition to the LEDs and other electronic components, a  $200\ \Omega$  resistance (made up of one or more resistors) should be connected in series with the battery.

Upon completing a challenge, get the circuit checked and initialled.

**Challenge 1:** Construct a circuit with one LED.

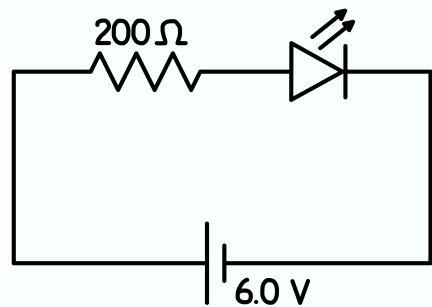

**Challenge 2:** Construct a circuit with two LEDs of the same colour in parallel.

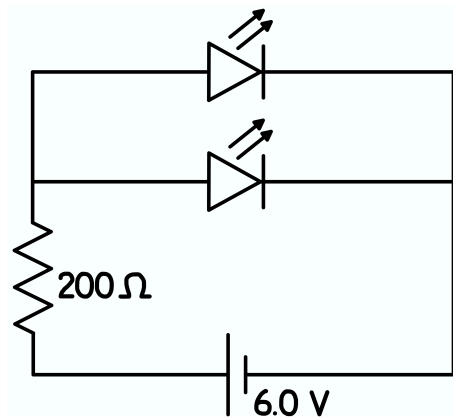

**Challenge 3:** Construct a circuit with one LED that lights up only when a pushbutton is pressed.

**Challenge 4:** Construct a circuit with two LEDs in series that toggle on and off with a slide switch.

**Challenge 5:** Using two switches, construct a circuit that lights up either a red, yellow or green LED depending on the position of the switches.

#### Challenge Checklist

1	2	3	4	5

The following challenges are optional and do not need to be checked.

**Challenge 6**

Using no additional wires aside from the ones used to power the breadboard, construct a circuit with three LEDs of the same colour in parallel

**Challenge 7**

Construct a circuit with one LED that turns off when a pushbutton is pressed.

**Challenge 8**

Construct a circuit with one LED with three brightness levels which are dependent on the positions of two slide switches.

**Challenge 9**

Using two push buttons, construct a circuit with one LED that lights up when either pushbutton is pressed (and is off when neither is pressed).

**Challenge 10**

Construct a circuit in which any combination of three LEDs can be turned on/off with slide switches but no lights are turned on if a pushbutton is pressed (regardless of switch position)