

1. An 6.0 kg object is on a frictionless ramp as shown. What is the acceleration of the object?

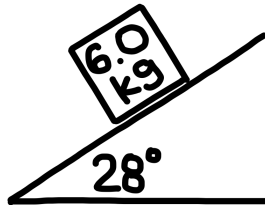

2. An object is on a ramp with a shown. If the coefficient of friction is 0.40, what is the acceleration of the object?

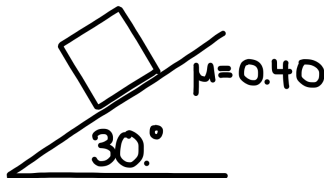

3. A 1.5 kg object is on a ramp as shown. If the object accelerates down the ramp at 3.0 m/s^2 , what is the coefficient of friction between the object and the surface of the ramp?

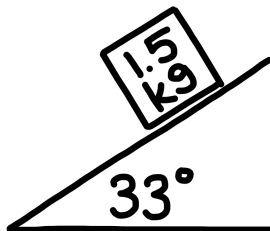

4. A 45 N force is applied to a 5.0 kg object as shown. If the coefficient of friction is 0.55, what is the acceleration of the object?

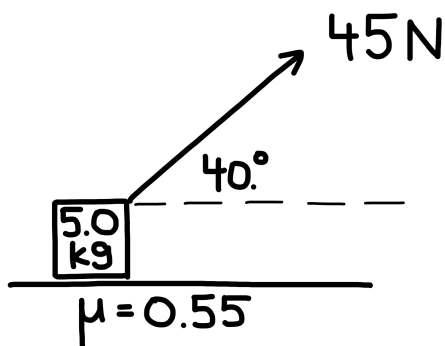

5. A 450 N force is applied to a 64 kg object as shown. If the coefficient of friction is 0.35, what is the acceleration of the object?

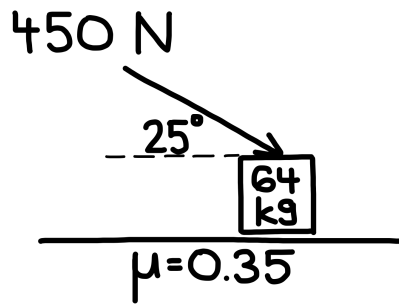

6. An object begins sliding down a ramp. If the object was initially at rest 1.5 m from the base of the ramp and the coefficient of friction is 0.30, how long does it take for the object to reach the bottom of the ramp?

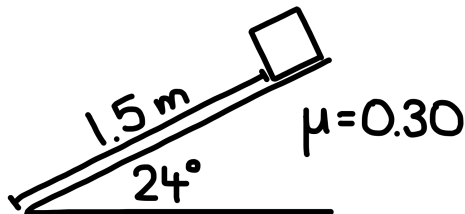

7. The coefficient of static friction between a 25 kg object and a surface is 0.55. Determine the minimum force needed to move the object from rest if the force is applied at an angle of 35 degrees above the horizontal.

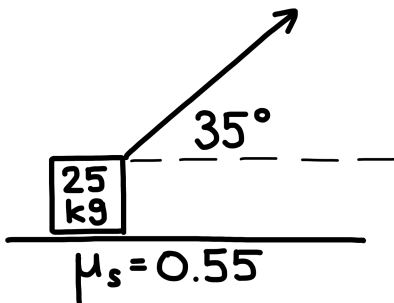

8. A 16 kg object is pushed up a ramp with a 150 N force applied parallel to the ground as shown. If the coefficient of friction is 0.40, what is the acceleration of the object?

